

Simionato Logic S



Features

- Flexibility for packaging various products in a large range of bag shapes: d-bag, quad, block bottom, pillow
- High performance sealing via servo driven jaws
- Duplex footprint occupies no more floorspace than a single system
- Available in right or left hand versions
- Stainless steel construction available
- Multiple jaw configurations
- Modular design for easy changeover allows future reconfigurations
- User-friendly HMI with interactive graphics
- Self-centering, stepper-driven pull belts

Simionato Logic S

Packaging Formats

Pillow bag, Flat bottom, D-bag, Quad bag, Recloseable Packages

High Performance

The Logic S offers important benefits for high speed, with adjustable sealing force and easy format changes. Available in right and left-hand versions, the duplex footprint occupies no more floorspace than a single system. For severe environmental conditions, a stainless steel AISI 304/316 is available. The Logic S 450 is capable of holding reels up to 880mm (34.6"), ideal for large format packaging. The intuitive HMI allows for easy set up and control of the machine. Advanced statistics and continuous calculations combine to guarantee maximum precision of every machine cycle.

Standard Features

- Environmental protection by fully enclosed construction
- Quick film change with pneumatic spindles
- Vacuum assisted splice table for quick film change
- Compact film path with adjustable film tension
- Low film and film runout detect
- Easy setup via user-friendly HMI with interactive graphics
- 100 recipe memory
- Adjustable sealing force via HMI panel
- Jaw speed independently adjustable
- Real time parameter adjustment
- Automatic film tracking
- Photo eye registration
- Encoder for precise control of the bag length
- Alarm history

Production Rate

Up to 130 packages per minute

Package Range

Model 350

Minimum width: 55mm (2.16")

Maximum width: 310mm (12.2")

Model 450

Minimum width: 140mm (5.5")

Maximum width: 400mm (15.75")

Power Requirements

480 Vac, 3 Ph, 50/60 Hz

Options

- Gas Flushing
- Polyethylene Sealing
- Anti-Bridging Device
- Anti-Static System
- Punch for Euroslot or Round Holes
- Tear Notch for Easy Opening
- Printers
- Metal Detector
- Duplex Configuration
- Right or Left-Hand Configuration
- Product Settling Device
- Stainless Steel Construction
- Auto-Splice
- Lower Flap Folder (Heated or Non-Heated)

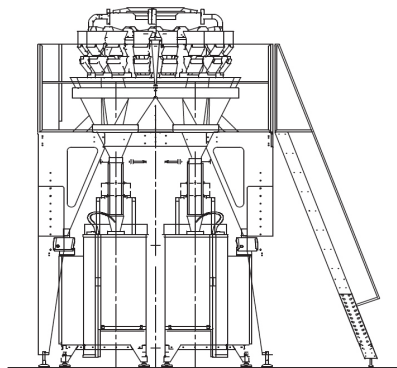

Duplex Slimline Footprint



Sealing Jaw Area



Custom solutions for integrated scales, augers and volumetrics

Hayssen Flexible Systems S.r.l
Via Trieste, 53 | Mestrino (PD) | 35035
ITALY
t. +39 049 9006511

Schib Packaging S.r.l.
Viale del Lavoro
7/9 A | Monte di Malo (VI) | 36030
ITALY
t. +39 0445 602300

BW Flexible Systems
101 Lilac Grove | Nottingham | NG9 1PF
UNITED KINGDOM
t. +44 (0) 115 967 8787

Hayssen | Hudson-Sharp | Rose Forgrove | Sandiacre | Schib | Simionato | SYMACH | Thiele