

Schib CO 90E



Features

- High Speed wrapper for hard candy and chewing gum
- Up to 2,000 ppm
- User-Friendly Controls
- Allen-Bradley programmable automation controller
- 10" color touch screen offering HMI functionality
- Allen-Bradley Kinetix servo drives
- Feeding Disk
- Twin reel holders (automatic splicer as an option)
- Reel run out sensor
- Motorized film pre-feed
- Photocell registration for printed films
- Serrated end seals for easy opening
- Temperature control integrated into control panel
- 2 to 6 jaws configurations

Schib CO 90E

The state-of-the-art Schib CO 90E is a horizontal flow-pack machine specifically designed for candies and other small size confectionery products such as pellets, bubble gums, lozenges, toffees, tablets and lollipops. Its design evolves from 50 years of industry expertise and engineering excellence, coupled with the ultimate automation and motion solution from Allen-Bradley.

Several configurations of this model are available, including lollipop versions, customized feeders for hard-boiled candies, molded products and marshmallows, and multi-feeders for balls to be wrapped in assorted colors.

Schib's key strength is long-term customer relationships based on consistent performance and after-sales support that surpasses expectations. We provide complete service, from design concept to installation and commissioning, followed by lifetime support.

Feature	Standard	Optional
Min./Max. product dimensions	Length 15 / 50 mm Width 5 / 50 mm Height 1 / 30 mm	
Performance	1500 ppm	Up to 2000 ppm
Film roll width and max. ext. dia	150 mm / 350 mm	
Drive	4 servo + 3 asynchronous motors	
Sealing head	Rotary	
In-feed conveyor useful length	1000 mm	On request
Automatic film splicer	No	Yes
Machine exit	Static chute	Exit belt
Control panel	Color touch-screen	
Program memory	40 programs	99 programs
Diagnostics	Yes	
Machine finishing	Painted RAL 9007	Stainless steel
Product sorting unit	No	Yes
Wrapping materials	Heat sealable OPP - BOPP - COEX laminate	Cold-sealable films
Installed / absorbed power	10 / 4 kW	
Weight	1500 kg	
Feeding system	Feeding disk	
Machine dimensions	4178 x 1463 x 1740 mm	
We reserve the right to make technical changes without prior notice.		



Ideal for Hard and Soft Candies



Feeding Disk

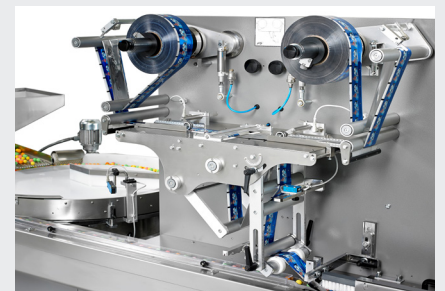

Automatic Film Splicing (optional)

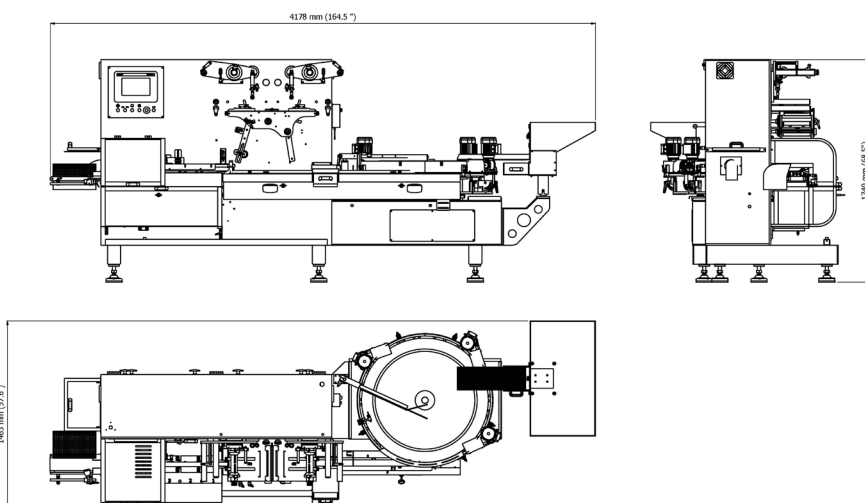

BW Flexible Systems
225 Spartangreen Blvd.
Duncan | SC | 29334
UNITED STATES
t. +1 (864) 486 4000
bwflexiblesystems.com

BW Flexible Systems UK Ltd.
101 Lilac Grove | Nottingham | NG9 1PF
UNITED KINGDOM
t. +44 (0) 115 967 8787
bwflexiblesystems.com

Hayssen Flexible Systems S.r.l.
Via Trieste, 53 | Mestrino (PD) | 35035
ITALY
t. +39 049 9006511
hayssen.com

Schib Packaging S.r.l.
Viale del Lavoro, 7/9 A
Monte di Malo (VI) | 36030
ITALY
t. +39 0445 602300
schib.it

Hayssen | Hudson-Sharp | Rose Forgrove | Sandiacre | Schib | Simionato | Symach | Thiele

BW Flexible Systems is a global manufacturer of packaging systems that fill and bag thousands of food and non-food products. Our packaging systems are designed and manufactured to maximize the efficiency and lifetime value of our customers' packaging lines. Our range of machinery includes form-fill-seal, feeding, bag filling and sealing, pouch-making equipment, flow-wrap, reclosable packaging solutions, palletizing, stretch-wrapping and more. For more information, go to bwflexiblesystems.com