

# Schib CO 50 BBTG



## Features

- Box motion HFFS technology suitable for standard and modified atmosphere packaging
- Bottom film feed
- Hygienic and easy-to-clean design suitable for a wide range of food and non-food products
- 7" color touch screen offering user-friendly HMI functionality
- Icon-based operator interface with real time diagnostics
- 500 mm film width (700 mm as an option)
- All product contact parts are made of stainless steel or food grade plastic
- Stainless steel construction on demand
- Independent temperature control circuits incorporated into the control panel
- Product-specific infeeds and automatic feeders are available on demand

# Schib CO 50 BBTG

The Schib CO 50 BBTG is an inverted horizontal flow wrapper featuring box motion HFFS technology. The machine is suitable for a wide range of food and non-food products, for both standard and modified atmosphere packaging.

In conjunction with MAP barrier films, the machine can deliver high integrity seals suitable for gas flush applications, to extend the shelf life of many food products.

Ideal not only for products that require hermetic sealing, but also for difficult-to-handle items or products for the medical industry.

Full servo version with multi-axis electronic drive system.

Feature	Standard	Optional
Min/Max product length	Length 50 / 800 mm	Length > 800 mm
Min/Max product width	Width 10 / 200 mm	Width 5 / 300 mm
Min/Max product height	Height 10 / 120 mm	
Performance	70 ppm	
Film roll width	500 mm	700 mm
Film roll max. ext. diameter	350 mm	
Drive	4 axes	5 axes
Sealing head	Box motion	
In-feed conveyor useful length	1500 mm	On request
Automatic film splicer	No	Yes
HMI	7" color touch-screen	10" color touch-screen
Program storage	40 programs	Expandable
Machine finishing	Painted RAL 9007	Stainless steel
Wrapping materials	Heat sealable OPP - BOPP - COEX - Laminate - Barrier films	LDPE - HDPE - Polyolefin - Cold sealable films
Installed / absorbed power	8 / 3 kW	
Weight	1200 kg	
Feeding system	Manual	Automatic
Machine dimensions L x W x H	5175 x 1450 x 1820 mm	
We reserve the right to make technical changes without prior notice.		

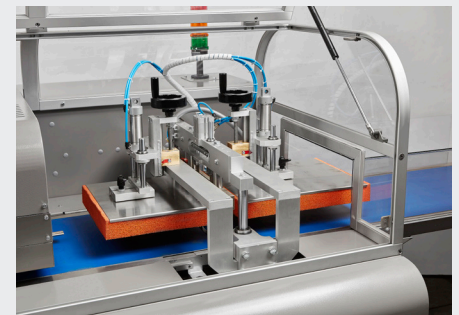

Box Motion Sealing Head

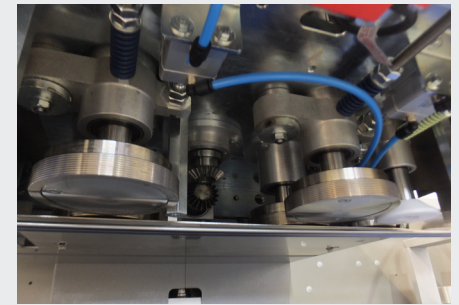

Overhead Sealing Wheels Assembly

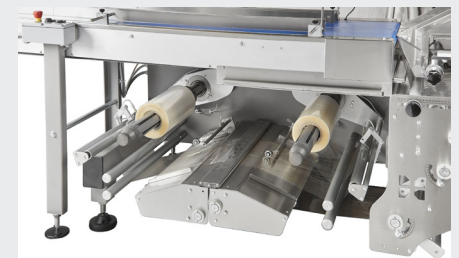

Automatic Reel-to-Reel Splice Option

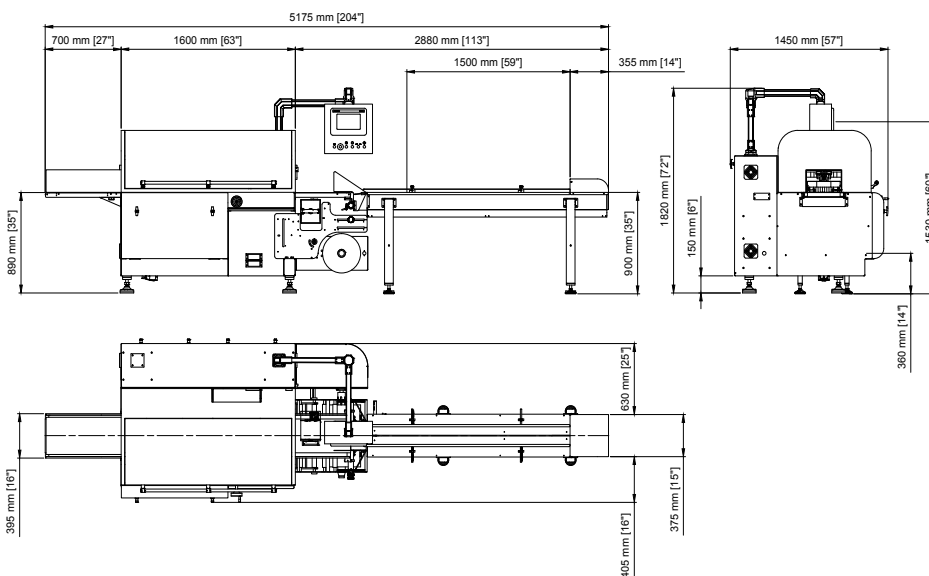

BW Flexible Systems  
225 Spartangreen Blvd.  
Duncan | SC | 29334  
UNITED STATES  
t. +1 (864) 486 4000  
[bwflexiblesystems.com](http://bwflexiblesystems.com)

BW Flexible Systems UK Ltd.  
101 Lilac Grove | Nottingham | NG9 1PF  
UNITED KINGDOM  
t. +44 (0) 115 967 8787  
[bwflexiblesystems.com](http://bwflexiblesystems.com)

Haysen Flexible Systems S.r.l.  
Via Trieste, 53 | Mestrino (PD) | 35035  
ITALY  
t. +39 049 9006511  
[haysen.com](http://haysen.com)

Schib Packaging S.r.l.  
Viale del Lavoro, 7/9 A  
Monte di Malo (VI) | 36030  
ITALY  
t. +39 0445 602300  
[schib.it](http://schib.it)

Hayssen | Hudson-Sharp | Rose Forgrove | Sandiacre | Schib | Simionato | Symach | Thiele

BW Flexible Systems is a global manufacturer of packaging systems that fill and bag thousands of food and non-food products. Our packaging systems are designed and manufactured to maximize the efficiency and lifetime value of our customers' packaging lines. Our range of machinery includes form-fill-seal, feeding, bag filling and sealing, pouch-making equipment, flow-wrap, reclosable packaging solutions, palletizing, stretch-wrapping and more. For more information, go to [bwflexiblesystems.com](http://bwflexiblesystems.com)

